

INTRODUCTION TO MEASUREMENT UNCERTAINTY

March 19, 2003

American Society for Quality Section 904

Muncie, Indiana

Presented by:

Dilip A. Shah

E = mc³ Solutions

197 Great Oaks Trail #130

Wadsworth, Ohio 44281-8215

(330) 328-4400

Measurement Uncertainty Definitions

Uncertainty: “The condition of being uncertain. The estimated amount or percentage by which an observed or calculated value may differ from the true value.” -*American Heritage Dictionary*

Measurement Uncertainty Definitions

From measurement point of view:

“Doubt expressed in a quantifiable way about the validity of the result of the measurement.”

Measurement Uncertainty Definitions

“A parameter, associated with the result of a measurement, that characterizes the dispersion of the values that could reasonably be attributed to the measurand.” ***-International Vocabulary of Basic and General Term in Metrology***

Measurement Uncertainty Definitions

- **Uncertainty** of measurement is a parameter, associated with the result of a measurement, that characterizes the dispersion of the values that could reasonably be attributed to the measurand. It can also be expressed as an estimate characterizing the range of values within which the true value of a measurand lies.

Measurement Uncertainty Definitions

Standard Uncertainty of Measurement:

"The uncertainty of measurement expressed as the standard deviation."

-Guide to Expression of Uncertainty in Measurement

*Why is it important to understand
Measurement Uncertainty?*

- **Because it is a good practice. Without knowing the capability of your measurement, you are not measuring what you think you are measuring.**

*Why is it important to understand
Measurement Uncertainty?*

- **Various Standards and Guides require you to understand, quantify and report Measurement Uncertainties of your calibration processes.**

ISO 17025 5.4.6.1

A calibration laboratory, or a testing laboratory performing its own calibration, shall have and shall apply a procedure to estimate the uncertainty of measurement for all calibrations and types of calibrations.

ISO 17025 5.4.6.2

Testing laboratories shall have and shall apply procedures for estimating uncertainty of measurement. In certain cases the nature of the test method may preclude rigorous, metrologically and statistically valid, calculation of uncertainty of measurement. In these cases the laboratory shall at least attempt to identify all the components of uncertainty and make a reasonable estimation, and shall ensure that the form of reporting of the result does not give a wrong impression of the uncertainty. Reasonable estimation shall be based on knowledge of the performance of the method and on the measurement scope and shall make use of, for example, previous experience and validation data.

ISO 17025 5.4.6.3

When estimating the uncertainty of measurement, all uncertainty components which are of importance in the given situation shall be taken into account using appropriate methods of analysis.

- **MEASUREMENT UNCERTAINTY IS ALSO MENTIONED ELSEWHERE IN THE ISO 17025 STANDARD**

Mathematical Concepts

- **Basic knowledge of mathematics and statistics is required to determine Measurement Uncertainty.**

Metrology Concepts

- **Traceability**
- **National Standards (NIST, CSA, NPL etc.)**
- **Accuracy Ratios vs. Uncertainty Ratios**
- **Measurement Uncertainty**
- **Calibration**
- **Environmental factors**

Metrology Concepts

- **Traceability** means that a measured result can be related to stated references, usually national or international standards, through an unbroken chain of comparisons, all having stated uncertainties.

Standards and Practices

- **ISO 17025 Requirements**
- **Additional accrediting body requirements (e.g. A2LA, LAB, NVLAP etc.)**
- **Guide to Uncertainty of Measurement (GUM)**
- **Good Laboratory Management Practices**

Guide to Uncertainty of Measurement (GUM)

- **NIST 1297:1994**
- **ANSI/NCSLI Z540-2: 1997**
(Americanized version of G.U.M.)
- **ISO Guide to Uncertainty of Measurement (GUM)**

Good Laboratory Management Practices

- **Use of SPC and other statistical techniques.**
- **Use of check standards**
- **Proficiency testing**
- **Interlaboratory Comparisons**
 - **ISO Guide 43, ASTM E1301**

7 Steps for Determining Measurement Uncertainty

Note: Ensure that the *process of determining uncertainties is under statistical control before starting.*

1. Identify the uncertainties in the measurement process.
2. Classify type of uncertainty (A or B).
3. Quantify (evaluate and calculate) individual uncertainty by various methods.
4. Document in an uncertainty budget.
5. Combine uncertainty (Root Sum Square (RSS) method).
6. Assign appropriate k factor multiplier to combined uncertainty to report expanded uncertainty.
7. Document in an Uncertainty report with the appropriate information (add notes and comments for future reference).

Standard Uncertainty Calculations

Uncertainty Calculations

- **Primary calculations encountered are:**
 - **Basic statistics (mean, range std. dev. variance etc.)**
 - **Standard Deviations (Sample and Population)**
 - **Other statistical methods may be useful:**
 - **Analysis of Variance**
 - **Gage R. & R.**
 - **Design of Experiments (DOE)**
- **Knowledge of process is important.**

Identify The Uncertainties In The Measurement Process.

Determine contribution of factors affecting the measurement process.

For example:

Environment

Measuring Equipment

Measurement Setup, Method, Procedure

Operator

Software, Calculation Method

Other constraints

Classify Type Of Uncertainty (A or B)

Uncertainty Evaluation Methods

Assess uncertainty (and assign uncertainty type A or B).

Type A evaluation method:

The method of evaluation of uncertainty of measurement by the statistical analysis of series of observations.

Examples:

_ Standard Deviation of a series of measurements

_ Other statistical Evaluation methods (GAGE R. & R., ANOVA, DOE)

Classify Type Of Uncertainty (A or B)

Uncertainty Evaluation Methods

Assess uncertainty (and assign uncertainty type A or B).

Type B evaluation method:

The method of evaluation of uncertainty of measurement by means other than the statistical analysis of series of observations.

Examples:

- _History of parameter
- _Other knowledge of the process parameter
- _Based on specification

Quantify (evaluate and calculate) Individual Uncertainty By Various Methods.

Calculate Uncertainty

Document In An Uncertainty Budget.

Uncertainty Budget Example:

<u>TYPE A UNCERTAINTY</u>	<u>STD Uncert</u>	<u>Variance</u>
Air Density	2.38E_05	5.66E_1
Repeated Observations	1.58E_02	2.50E_04
Indication	2.89E_03	8.35E_06

<u>TYPE B UNCERTAINTY</u>	<u>STD Uncert</u>	<u>Variance</u>
Weights	2.04E_02	4.16E_04
Density of Weights	1.30E_05	1.69E_10
Gravity Acceleration	2.05E_05	4.20E_10
Length of Arm	3.20E_04	1.02E_07
Temperature	6.93E_07	4.80E_13

Combine Uncertainty (Root Sum Square (RSS) method).

$$u_{c_a} = \sqrt{u_{c_{a1}}^2 + u_{c_{a2}}^2 + \dots}$$

$$u_{c_b} = \sqrt{u_{c_{b1}}^2 + u_{c_{b2}}^2 + \dots}$$

Combine Uncertainty (Root Sum Square (RSS) method).

$$u_c = \sqrt{u_{c_a}^2 + u_{c_b}^2}$$

Assign Appropriate k Factor Multiplier To Combined Uncertainty To Report Expanded Uncertainty.

$$U = k \cdot u_c$$

Assign Appropriate k Factor Multiplier To Combined Uncertainty To Report Expanded Uncertainty.

- k factor is normally 2 for approximately 95% confidence interval for infinite degrees of freedom.

- However, it may differ based on effective degrees of freedom

Effective Degrees of Freedom

$$V_{eff} = \frac{u_c^4(y)}{\sum_{i=1}^N \frac{c_i^4 u^4(x_i)}{v_i}}$$

Welch-Satterthwaite Formula

Uncertainty Report

	Company				
	Name				
	Parameter				
	Nominal or Range				
	Primary Equipment				
	Personnel				
	Date				
	Additional Equipment				
Type A Uncertainty					
	Uncertainty Description	Uncertainty	Distribution	Divisor	Standard Uncertainty Variance
1					
2					
3					
Combined Type A Uncertainty					
Type B Uncertainty					
	Uncertainty Description	Uncertainty	Distribution	Divisor	Standard Uncertainty Variance
1					
2					
3					
Combined Type B Uncertainty					
Combined Uncertainty Results					
	TYPE A Standard Uncertainty		Distribution	Divisor	1/Divisor
	TYPE A Variance		Rectangular	1.7321	0.5774
			Triangular	2.4495	0.4082
			U - Shaped	1.4142	0.7071
	TYPE B Standard Uncertainty				
	TYPE B Variance				
			Coverage Factor (k)	Confidence Level	
			1.000	68.27	
	TYPE AB (Combined) Standard Uncertainty		1.645	90.00	
	TYPE AB (Combined) Variance		1.960	95.00	
			2.000	95.45	
	Effective Degrees of freedom		2.576	99.00	
	Coverage Factor (k)		3.000	99.73	
	Expanded Uncertainty				
Comments					

Uncertainty Distributions

- **4 distributions are normally encountered when estimating Uncertainty:**
 - **Normal (Gaussian)**
 - **Rectangular**
 - **Triangular**
 - **U – shaped (trough)**

Uncertainty Distributions

- Normal Distribution

Normal distribution is one way to evaluate uncertainty contributors so that they can be quantified and budgeted for. It allows a manufacturer to take into account prior knowledge, manufacturer's specifications, etc. Normal distribution helps understand the magnitude of different uncertainty factors and understand what is important.

- **The normal distribution is used when there is a better probability of finding values closer to the mean value than further away from it, and one is comfortable in estimating the width of the variation by estimating a certain number of standard deviations.**

Uncertainty Distributions

- Rectangular Distribution

Rectangular distribution is fairly conservative. The manufacturer has an idea of the variation limits, but little idea as to the distribution of uncertainty contributors between these limits. It is often used when information is derived from calibration certificates and manufacturer's specifications.

- **the information found in calibration certificates, certificates of compliance and manufacturers' specifications.**

Uncertainty Distributions

- **Triangular Distribution**

Triangular distribution is most often used in evaluations of noise and vibration. The manufacturer must be more comfortable estimating the width of variation using "hard" limits rather than a certain number of standard deviations.

Typical examples of where triangular distribution is used are noise and vibration

Uncertainty Distributions

- U-shaped Distribution

U-shaped distribution is not as rare as it seems.

Cyclic events, such as temperature, often yield uncertainty contributors that fall into this sine wave pattern.

- **U-shaped distribution is the probability density function for a sine wave. Cyclic influences, such as temperature variation, usually follow a sine wave pattern.**

Uncertainty Distributions

- **One cannot combine normal (Gaussian) and non-normal distributions when combining uncertainties.**
- **Correction factors apply when combining normal and non-normal distributions.**

Uncertainty Distributions

Correction factors

Distribution	Divide by	Divisor
Rectangular	Square-root 3	1.7321
Triangular	Square-root 6	2.4495
U - Shaped	Square-root 2	1.4142
Coverage Factor (k)	Confidence Level	
1	68.27	
1.645	90	
1.96	95	
2	95.45	
2.576	99	
3	99.73	

Analyzing and Reporting Uncertainty

- Understand the mechanics and analysis of data calculations.
- Follow the format outlined in the next slide as a start.

Uncertainty Report

Company							
Name							
Parameter							
Nominal or Range							
Primary Equipment							
Personnel							
Date							
Additional Equipment							

Type A Uncertainty							
Uncertainty Description	Uncertainty	Sensitivity	Distribution	Degrees of Freedom	Divisor	Standard Uncertainty	Variance
1							
2							
3							
4							
5							
6							
7							

Combined Type A Uncertainty

Type B Uncertainty							
Uncertainty Description	Uncertainty	Sensitivity	Distribution	Degrees of Freedom	Divisor	Standard Uncertainty	Variance
1							
2							
3							
4							
5							
6							
7							

Combined Type B Uncertainty

Combined Uncertainty Results	
TYPE A Standard Uncertainty	
TYPE A Variance	
TYPE B Standard Uncertainty	
TYPE B Variance	
TYPE AB (Combined) Standard Uncertainty	
TYPE AB (Combined) Variance	
Effective Degrees of freedom	
Coverage Factor (k)	
Expanded Uncertainty	

Distribution	Divide by	Divisor	1/Divisor
Rectangular	Square-root 3	1.7321	0.5774
Triangular	Square-root 6	2.4495	0.4082
U - Shaped	Square-root 2	1.4142	0.7071

Coverage Factor (k)	Confidence Level
1.000	68.27
1.645	90.00
1.960	95.00
2.000	95.45
2.576	99.00
3.000	99.73

Comments

The above gives a process flow of calculations

Analyzing and understanding Calibration Reports

- **For a Test Uncertainty Ratio of 4:1, the certification standard uncertainty has to be 4 times better than the uncertainty of the unit under calibration.**
- **The Test Uncertainty Ratio must be based on the same level of confidence.**

Analyzing and understanding Calibration Reports

Test Uncertainty Ratio (T. U. R.)

Vs.

Test Accuracy Ratio (T. A. R.)

Analyzing and Understanding Calibration Reports

Test Accuracy Ratio

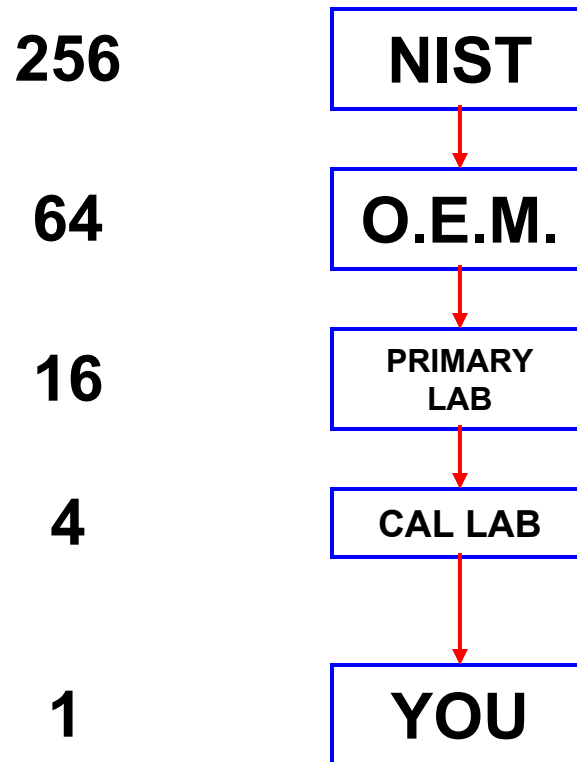

Analyzing and understanding Calibration Reports

Uncertainties

Test Uncertainty Ratio

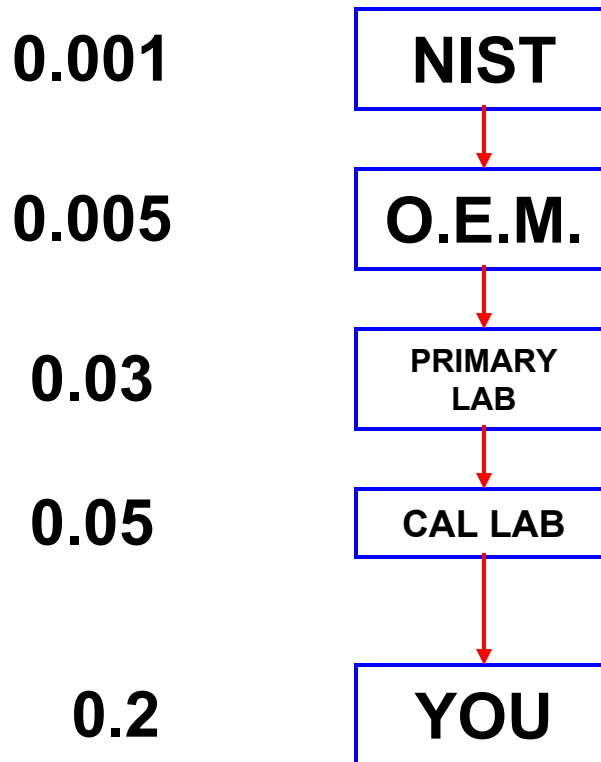

Applying Uncertainty Data

- Calibration reports
- Test reports
- Uncertainty data is cumulative (hierarchical) – see previous slide
- Test Uncertainty Ratios (T.U.R.)

Standard Uncertainty Calculations

Worked Example

Micrometer Measurement Uncertainty

Micrometer Resolution: 0.00001 inch

Gage Block Specification: +/- 0.000003 in.

Coefficient of Thermal Expansion of gage Block: 0.000002 in/in/°C

Controlled Temperature in laboratory environment: 20 °C +/- 2 °C

Micrometer Measurement Uncertainty

Type A Uncertainty						
Uncertainty Description	Uncertainty	Distribution	Degrees of Freedom	Divisor	Standard Uncertainty	Variance
Micrometer Repeatability (0.9000" gage Block)	1.80E-05	n	9	1	1.80E-05	3.24E-10
Combined Type A Uncertainty					1.80E-05	3.24E-10
Type B Uncertainty						
Uncertainty Description	Uncertainty	Distribution	Degrees of Freedom	Divisor	Standard Uncertainty	Variance
Gage Block Specification: +/- 0.0000003 in.	3.00E-06	r	infinite	1.7321	1.73E-06	3.00E-12
Coefficient of Thermal Expansion of gage Block: 0.000002 in/in/C	7.20E-06	u	infinite	1.4142	5.09E-06	2.59E-11
Micrometer Resolution	1.00E-05	r	infinite	1.7321	5.77E-06	3.33E-11
Combined Type B Uncertainty					7.89E-06	6.23E-11

Micrometer Measurement Uncertainty

Combined Uncertainty Results					
TYPE A Standard Uncertainty	1.80E-05	Distribution	Divide by	Divisor	1/Divisor
TYPE A Variance	3.24E-10	Rectangular	Square-root 3	1.7321	0.5774
		Triangular	Square-root 6	2.4495	0.4082
		U - Shaped	Square-root 2	1.4142	0.7071
TYPE B Standard Uncertainty	7.89E-06				
TYPE B Variance	6.23E-11				
		Coverage Factor (k)	Confidence Level	Coverage Factor based on Eff. df	
		1.000	68.27	2.18	
TYPE AB (Combined) Standard Uncertainty	1.97E-05	1.645	90.00		
TYPE AB (Combined) Variance	3.86E-10	1.960	95.00		
		2.000	95.45		
Effective Degrees of freedom	12.79	2.576	99.00		
Coverage Factor (k)	2	3.000	99.73		
Expanded Uncertainty	3.93E-05				

Questions???